



THE CANTER.
Made for business.



WHATEVER THE CHALLENGE, THERE'S A CANTER THAT'S UP FOR IT.

FUSO Canter offers the ultimate range of light-duty trucks, designed for the modern urban environment and made for business.

In city streets, on busy worksites or out on the highway – anywhere performance, agility and efficiency matter – the Canter range is right at home. Each Canter is a specialist, with its own strengths and advantages. Whatever your business priorities, there's one for you.

Where access to restricted space is high on the list, the 3.5t urban operator is as easy to manoeuvre and park as most vans, and you can drive it on a standard UK car licence. For bigger jobs, meet the 7.5t workhorse with its class-leading payload. The size of a 7.5t truck with the payload of a 10t truck, the Canter 8.55t weight lifter outperforms others in its class. When work takes you off-road, the all-wheel, all-rounder Canter 4x4 is your capable companion. For environmental credentials and impressive fuel economy, the Canter Eco Hybrid is a true efficiency champion.

As part of the Daimler Group, your FUSO Canter comes with a very reassuring additional feature – the Mercedes-Benz national Dealer network providing service and support and covering the whole of the UK. It's a network backed by over 80 years of commercial vehicle experience.

With Canter, the choice is yours. Four weight classes. Two cab variants. Three engines. Six wheelbases. Find out which one is perfect for your business, now.



CONTENTS.

The Canter range

Canter 3.5t	6
Canter 6.5t 4x4	8
Canter 7.5t	10
Canter 8.55t	12
Canter Eco Hybrid	14

Light-duty truck, heavy-duty backing	17
--------------------------------------	----

Our customer service	18
----------------------	----

The details

The cab	20
DUONIC®	22
Engines	23
All-wheel drive	24
Hybrid technology	25
Technical details	26





CANTER 3.5t

THE URBAN OPERATOR

If you're driving and working in the crowded streets of Britain's cities, Canter 3.5t does the job. With the smallest turning circle in its class and a neat cab width of 1.7m or 2m, it gets just about anywhere a van can go – and you can drive it on a standard UK car licence, with no special training. Spacious cabs and independent suspension ensure a comfortable ride, and the longest body length in its segment means there's plenty of room for the tools and materials of your trade. The Canter 3.5t – the real city slicker of the range.



CANTER 6.5t 4x4

THE ALL-WHEEL ALL-ROUNDER

When work takes you off-road – whether it's a building site in the city or a remote rural location – the Canter 6.5t 4x4 keeps you firmly on the ground. For winter service, or anywhere you're faced with steep gradients, it's a natural. Switching easily between two and four-wheel drive, the efficient 3.0-litre Canter 6.5t 4x4 delivers great fuel efficiency. With a robust ladder-type frame for diverse body solutions, it's ideal for public services, horticulture, landscaping and construction. Put it to the test, on and off-road.



CANTER 7.5T

THE WORKHORSE

If you need to make fewer journeys, or carry more materials per trip but you still need an easy-to-drive, agile truck that's at home in city streets, the Canter 7.5t delivers a market-leading payload. Developed for congested, urban environments, the 7.5t workhorse is available with DUONIC® transmission – the world's first dual clutch on a truck – as well as ESP and start-stop as standard. With a load bearing capacity of 5 tonnes, it's the Canter that lets you carry more.

CANTER 8.55T

THE WEIGHT LIFTER

With more than a tonne extra payload, the big brother of the Canter family gives you all the capability and refinement of the 7.5t plus crucial extra carrying power. Yet Canter 8.55t is still less than 2.2m wide and highly manoeuvrable, allowing access to zones restricted to the 10t limit. Perfect for brewery work, municipal projects or even emergency services – Canter 8.55t has the strength to deliver.



CANTER ECO HYBRID

THE EFFICIENCY CHAMPION

The Canter Eco Hybrid is a genuine pioneer: the first series-production hybrid light-duty truck in Europe. Generating energy as it brakes, the hybrid system reduces fuel consumption by up to 23%*. That can help you pay off the cost premium in a short timeframe while cutting emissions to impressively low levels. With a ten-year warranty on main battery components and the peace of mind that comes with 20 years of hybrid experience, we're your efficiency champion. If a healthy environment matters to you and your clients, the choice is clear.

*Versus a standard diesel engine.





FUSO CANTER

LIGHT-DUTY TRUCK, HEAVY-DUTY BACKING

FUSO is a proven global brand. Established in Japan in 1932, today it is one of the largest manufacturers of commercial vehicles in Asia, with branches in 150 countries on five continents, and a product portfolio covering all areas of deployment.

FUSO has been an integral element of Daimler Trucks since 2004 with the FUSO Canter being the only light-duty truck in Daimler's portfolio. With combined experience gained from more than 80 years of commercial vehicle manufacturing, Daimler and FUSO share a major goal: the development of new drive systems on the road to emission-free driving. FUSO has already set an important milestone with the Canter Eco Hybrid – the first series-production hybrid light-duty truck in Europe.

It's not only the environment that benefits from the two brands' cooperation and extensive experience. Together, we offer first-class service and access to a fully integrated sales and after-sales network. Ask your authorised FUSO or Mercedes-Benz Dealer for more information.

KEEPING YOUR BUSINESS MOVING: FUSO CUSTOMER SERVICE.

Canter is engineered for phenomenal reliability. The FUSO and Mercedes-Benz network is there to provide support when you need it, as well as helpful finance and leasing services.

With every new Canter you get a warranty for three years¹ or 100,000 km (whichever comes first), and the long maintenance interval of 40,000 km saves you time and money.



A network covering Britain and beyond. As part of the Daimler family, Canter is supplied and serviced through Mercedes-Benz and FUSO Dealers throughout the world. That includes 85 service locations the length and breadth of the UK (and 800 in Europe).



Parts and accessories. Genuine FUSO parts and accessories are the product of professional development expertise, top-class materials, excellent workmanship and functionality tailored exactly to the needs of the vehicle. By using genuine FUSO parts we guarantee quality down to the very last detail.

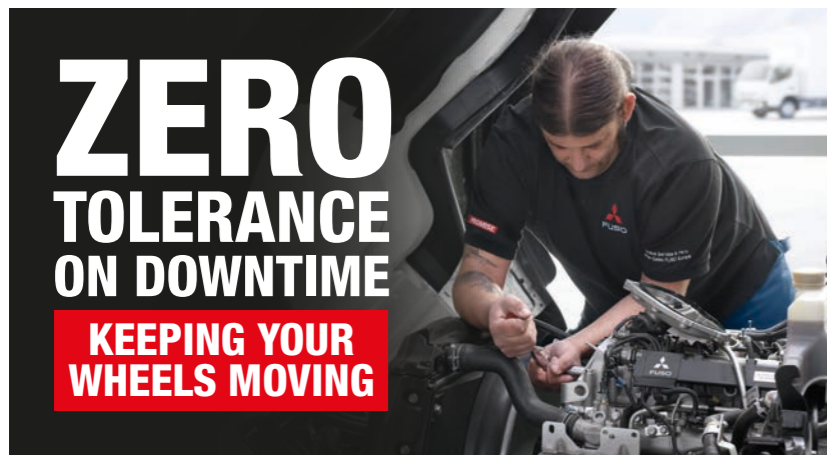

**ZERO
TOLERANCE
ON DOWNTIME**
**KEEPING YOUR
WHEELS MOVING**

Canter's Zero Tolerance on Downtime initiative will keep you moving, come what may. That's a promise. Zero Tolerance means we will get to breakdowns in 55 minutes on average. If your vehicle needs workshop attention, we will not rest until it is fixed – in fact 90% are repaired within 24 hours. That still leaves a few trucks that can't be fixed in a day. If yours is one of them, we'll replace it with a like-for-like vehicle², or pay you the financial rental equivalent. It comes at no extra cost if you run your Euro VI vehicle on a Complete Service Contract.

Maintenance packages. Even with the stricter Euro VI emission standard, maintenance intervals for the Canter have been stabilised at 40,000 km (or once a year). Items that require regular checks (oil, brake fluid and windscreen-washer fluid) are accessible in the cab, making inspections a quick, easy and clean task. Our tilt-cab design (for single cabs) also ensures trouble-free access to all engine parts.



¹ On the chassis, powertrain and components provided ex works.
² Euro VI, factory standard (on-road) trucks with a Complete Service Contract.

A CAB SO GOOD YOU WON'T WANT TO LEAVE IT.

The Canter is big on comfort. Inside, everything is tailored to the driver's and co-driver's comfort needs. The well-sprung, noise-insulated cab makes longer journeys just as pleasant as short trips. If you're involved in delivery work and have to get in and out frequently, you'll appreciate the low entrance, which has only one step.



The interior. Your favourite new workplace. The interior is impressively spacious, with room for three people and up to seven in the crewcab. A level cab floor and a shift lever integrated into the black and grey dashboard facilitate through-cab access. Ergonomic Isringhausen seats in black provide firm support and comfort, even on longer trips. A driver's suspension seat is available as an option.



Everything within easy reach. Ergonomically arranged stowage facilities and LED lighting on the roof liner provide a neat and tidy interior. The infinitely adjustable steering wheel with high-quality chrome applications, multifunction lever and optional cruise control, where available, can be positioned according to the individual driver's height, ensuring all important functions are easily reachable.

CLEVER DETAILS THAT MAKE THE DIFFERENCE.

Canter is big on practical benefits. Its functional operating system makes work as easy and comfortable as possible. From automatic or manual air conditioning to standard-specification Eco Mode and Hill Start Assist, all technical refinements within the system are deployed by clearly marked, easy-to-use controls.



The cab's climate control. For ideal in-cab conditions we offer a choice of a manual air-conditioning system or optional automatic climate control. There's separately controlled ventilation for the crewcab.



The cruise control function. Maintain a constant vehicle speed and keep to legal speed limits for relaxed driving even on longer trips. Optionally available for all models with the DUONIC® dual clutch transmission, except Canter Eco Hybrid.



Eco Mode and Hill Start Assist as standard. While DUONIC® always selects the right gear for the lowest fuel consumption, Eco Mode enables further fuel savings by means of early shifting. Hill Start Assist provides support when moving off on an uphill gradient with a heavy load.



Parking lock function and manual shift option. DUONIC® offers a parking lock function to secure your Canter when it's parked. You also have the option of manually shifting up and down through all six gears.

DUONIC. A NEW STANDARD IN DRIVING COMFORT.

Enjoy a smooth gearshift, with no power interruption and minimal wear. The second, enhanced generation of the DUONIC® transmission delivers comfortable driving and simple handling, plus intelligent solutions such as the crawl function for easier manoeuvring and Hill Start Assist to ensure the truck moves off smoothly on upward gradients. In conjunction with improved shifting logic, the idle start/stop function (ISS) and Eco Mode features (fitted as standard) help you drive more efficiently and sustainably, while making significant savings on fuel.

Shifting without loss of power. The Canter doesn't just comply with the Euro VI standard – thanks to the standard-fit idle start/stop function (ISS), it exceeds it. In addition, the new DUONIC® dual-clutch transmission ensures shifting without interruption of tractive power and without the frictional losses you get with conventional automatic transmissions.

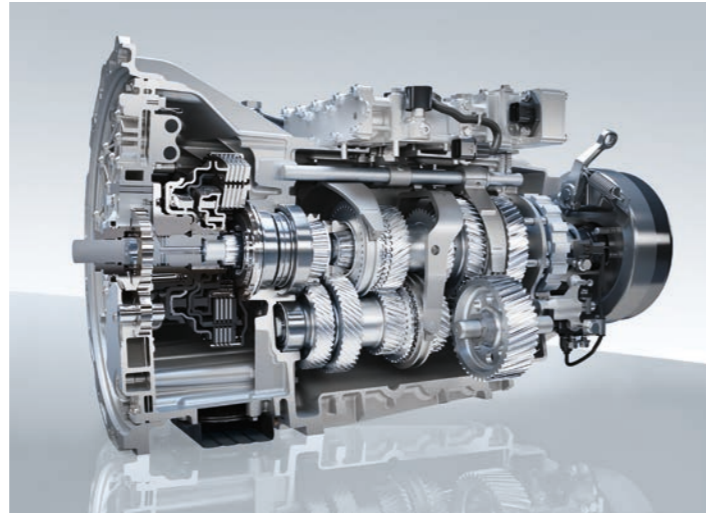

A CANTER FOR EVERY NEED.

Complete variability. Four weight classes, two cab types, three engine variants, six wheelbases, numerous items of special equipment ex-factory, plus manual transmission or DUONIC® dual-clutch transmission, as well as optional all-wheel drive or Eco Hybrid technology. With all that choice, it's easy to find the ideal Canter for you and your business.



The cab range and frame design. Canter lends itself to individual configurations, with a choice of a two-metre-wide Comfort single cab or Comfort crewcab with 3.5t, 6.5t, 7.5t or 8.55t GVW. Featuring sophisticated protection against corrosion and optimisation for weight, the frame has a very high load-carrying capacity. With six wheelbases, body lengths of up to 7.2m, high axle loads and a chassis load capacity of up to six tonnes, Canter gives you the ideal transport solution, whatever your business priorities.



The frame – robust and flexible. A common hole pattern on the ladder-type frame for all models makes the Canter extremely versatile, making it easier to attach a wide range of bodies. The optional 24-volt interface and various power take-offs available ex-factory – for driving hydraulic pumps or compressor units – ensure the Canter is game for anything.

A CLEAN DEAL: CANTER ENGINES.

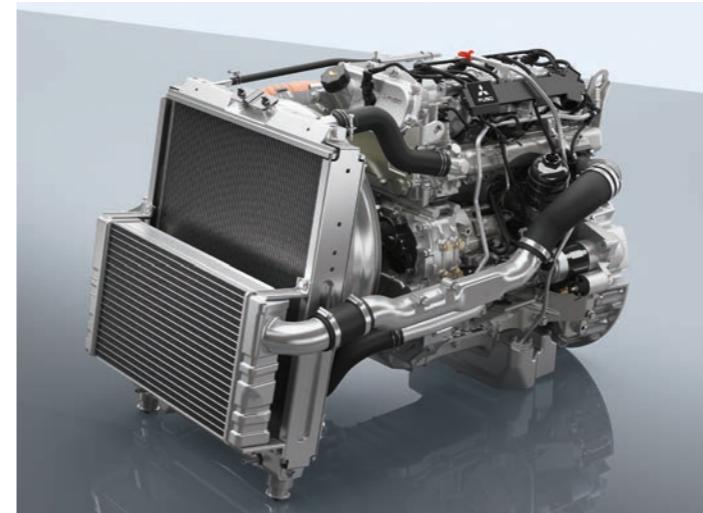

Diesel engine or hybrid drive – Canter sets new standards in technology and engineering. Featuring state-of-the-art common-rail technology and a variable-geometry turbocharger, the engine delivers high torque even at low revs. Add to this the advanced exhaust emission control system, the standard-fit idle start/stop function, new on-board diagnostics and new high-pressure fuel injection system. While you benefit from these innovations, so does the environment – especially with the unbeatable Eco Hybrid combination of an efficient 3.0-litre engine and a powerful electric motor.

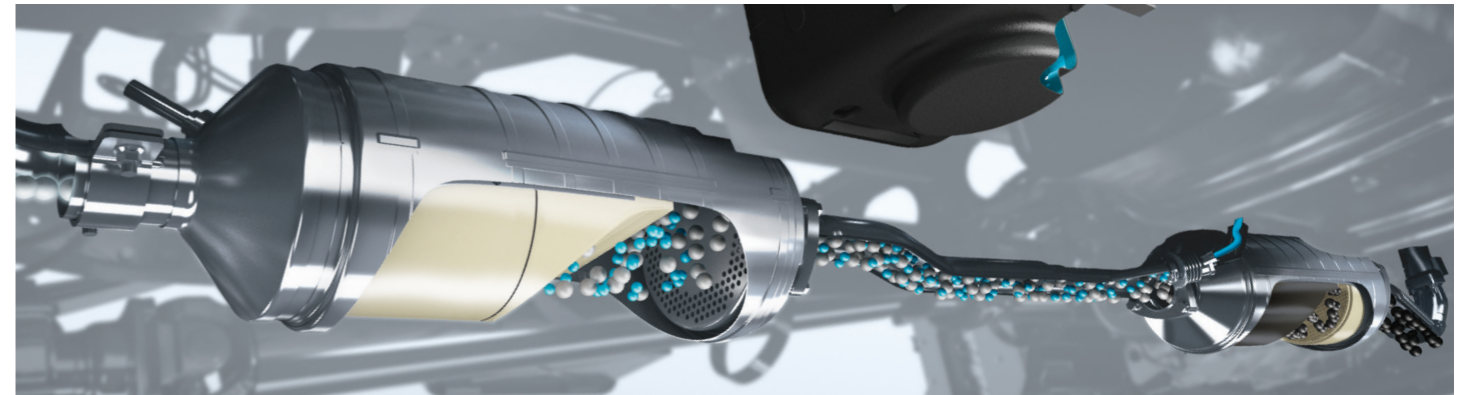

The emissions control system. All engine variants have a closed, maintenance-free diesel particulate filter which regenerates automatically – although you can do this manually if you need to. Exhaust gases are cleaned by a combination of oxidation catalytic converter and diesel particulate filter. Along with BlueTec® 6, the technology ensures all Canter models comply with the Euro VI standard.

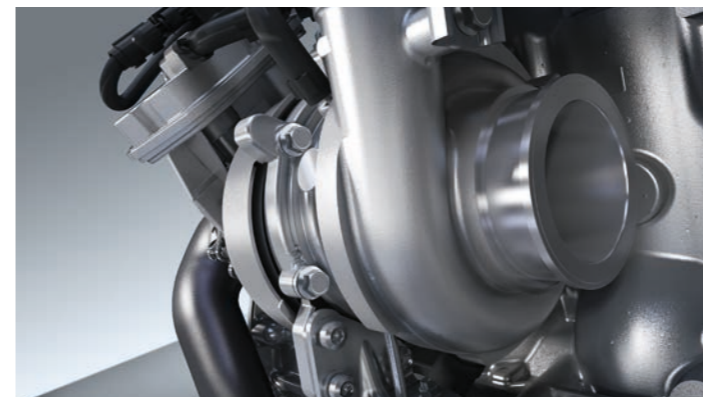

VGT and standard-fit exhaust brake. The variable-geometry turbocharger (VGT) optimises engine response and ensures constant high torque at low revs. The exhaust brake eases the strain on your vehicle's brake pads and discs, easing the braking system's workload on long downhill stretches.

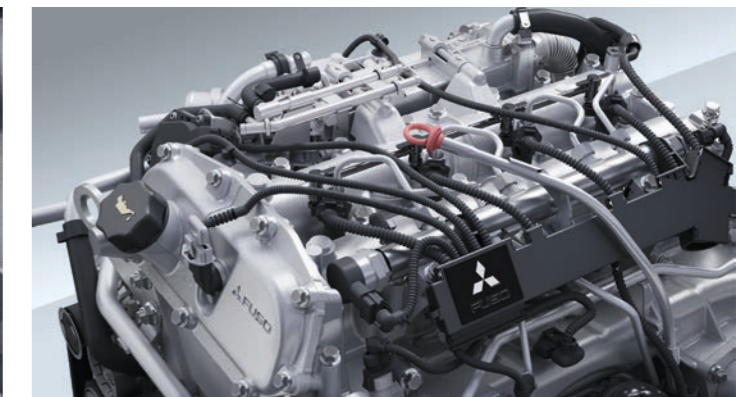

Three powerful engines. Three efficient and economical output ratings all offer improved torque curve at low revs, in every situation.

- 96 kW (130 hp)
- 110 kW (150 hp)
- 129 kW (175 hp)

ON AND OFF THE BEATEN TRACK. THE CANTER WITH ALL-WHEEL DRIVE.

In demanding terrain Canter 4x4's all-wheel drive gives you powerful traction and tremendous slope-climbing ability, while the high ground clearance and high payload and axle-loads provide brilliant off-road capability. With a single cab or crewcab, each with a choice of two wheelbases, Canter 4x4 uses an efficient 129 kW engine (175 hp) with BlueTec® 6 and a variable-geometry turbocharger (VGT) that ensures optimum response and high torque even at low revs.

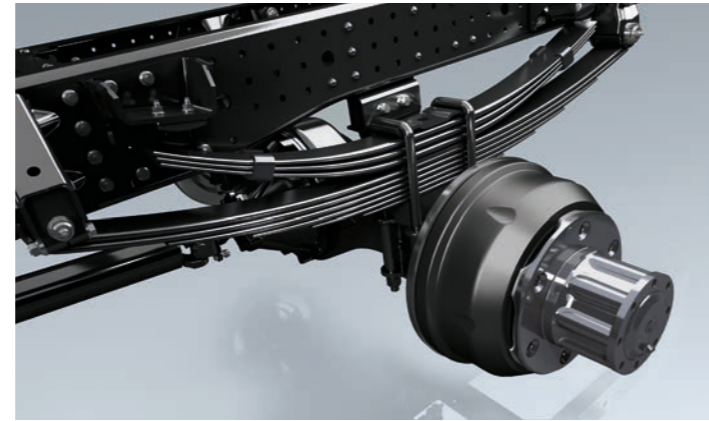
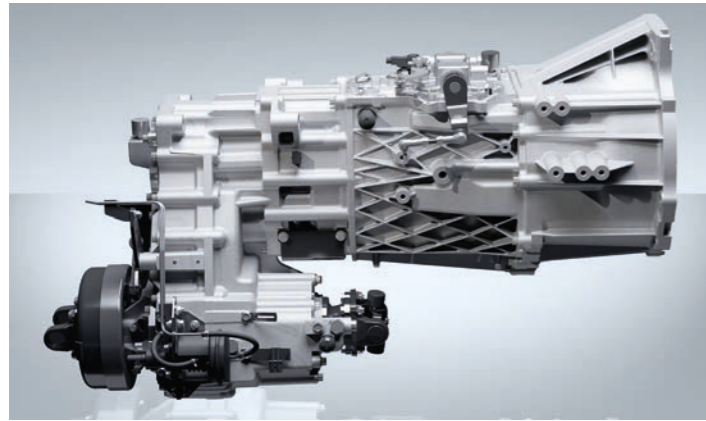

All-wheel drive. Equal distribution of power to front and rear axles gives all wheels high traction. All-wheel drive can be selected and deselected, making the system highly flexible and efficient. Even better traction is ensured by the self-locking differential, in conjunction with the selectable reduction gear. And when the front wheels are completely decoupled, wear, fuel consumption and turning circle diameter are reduced accordingly. Thanks to its wide gear-ratio spread, the transmission works equally well for slow driving in demanding off-road terrain, and higher speeds on the road.

The braking system provides firm intervention on the road and maximum deceleration in more demanding situations. Well protected against dust and dirt, the system features front and rear drums, ABS and electronic brake force distribution (EBD).



Payload capacity. The Canter 4x4 has a chassis load-bearing capacity of up to 3685 kg. With axle loads of up to six tonnes as well as an optional 24V interface and power take-offs ex-factory, a large choice of body options and solutions is available.

GENTLE ON THE ENVIRONMENT, EASY ON YOUR BUDGET.

The Canter Eco Hybrid is a milestone in the 20-year history of hybrid development at FUSO and Daimler. It is also the ideal vehicle to help you put your fleet on a more economical footing, while making a significant contribution to protecting the environment. The powerful hybrid drive featuring energy recovery, a start/stop system as standard and the DUONIC® dual clutch transmission means Canter Eco Hybrid can achieve fuel savings of up to 23%, resulting in lower CO₂ emissions as well as a significant reduction in running costs. Increased fuel efficiency means you should recoup the additional outlay within a short timeframe.

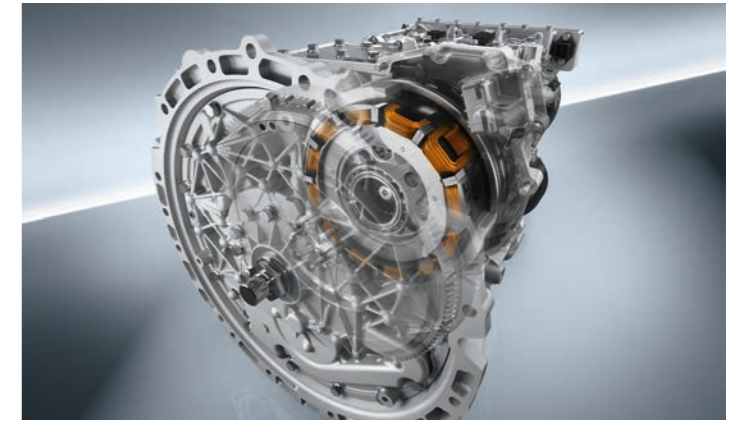
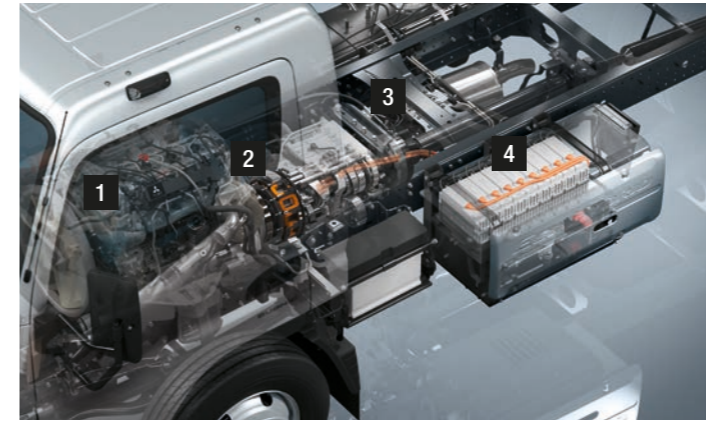

- 1 | Diesel engine 110 kW/370 Nm
- 2 | Electric motor 40 kW/200 Nm
- 3 | DUONIC® dual clutch transmission
- 4 | 2 kWh lithium-ion battery

The 40 kW electric motor. With a high regenerative capacity and wide torque range, the ultra-slim electric motor/generator works highly efficiently with the combustion engine to provide seamless performance.

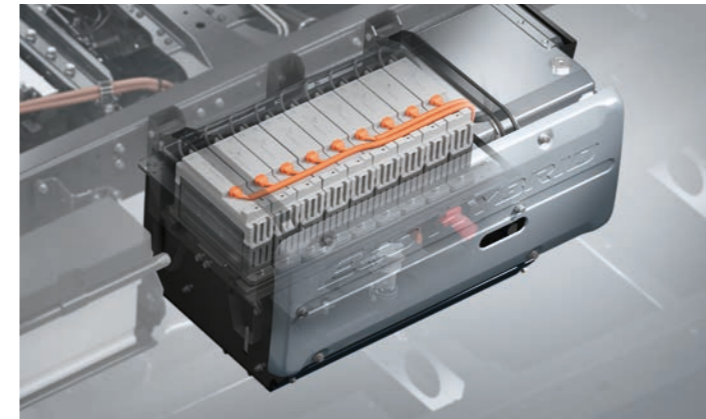

The 2 kWh lithium-ion battery. The battery has shown proven longevity and performance in practical, everyday use over many years. That's why we can provide you with a ten-year warranty on the major battery components.



The hybrid display. An easily legible display keeps the driver informed of battery charge status. An indicator shows when power is being consumed or generated, providing feedback to help modify driving style for the greatest efficiency.

TECHNICAL DETAILS – 4x2.

3.5t segment		3C13(D)				
Cab	Comfort					
Cab type/seats	Single/3			Crew/6		
Wheelbase (mm)	2500	2800	3400	3850	3400	
Chassis load-bearing capacity (kg)*	1475	1465	1435	1425	1245	
Perm. gross vehicle weight (kg)	3500					
Perm. gross combination weight (kg)	7000					
Max. output/max. torque	96kW (130hp)/300Nm					
Emission class	Euro VI					
Transmission	5-speed manual transmission/6-speed DUONIC® dual clutch transmission					
Turning circle (m)/track circle (m)	10.0/8.6	11.0/9.4	12.6/11.2	14.0/12.4	12.6/11.2	

3.5t segment		3C15(D)				
Cab	Comfort					
Cab type/seats	Single/3			Crew/6		
Wheelbase (mm)	2500	2800	3400	3850	3400	
Chassis load-bearing capacity (kg)*	1475	1465	1435	1425	1245	
Perm. gross vehicle weight (kg)	3500					
Perm. gross combination weight (kg)	7000					
Max. output/max. torque	110kW (150hp)/370Nm					
Emission class	Euro VI					
Transmission	5-speed manual transmission/6-speed DUONIC® dual clutch transmission					
Turning circle (m)/track circle (m)	10.0/8.6	11.0/9.4	12.6/11.2	14.0/12.4	12.6/11.2	

*with manual transmission

Front view

Comfort cab: 3C13(D), 3C15(D), 7C15(D), 7C18(D), 9C18

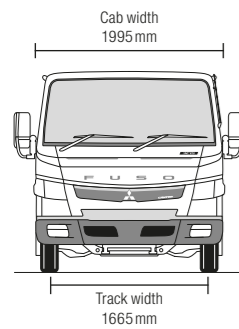

Top view

Single cab: 3C15, 7C15, 7C18, 9C15, 9C18

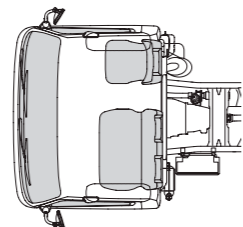

Crew cab: 3C13D, 3C15D, 7C15D, 7C18D

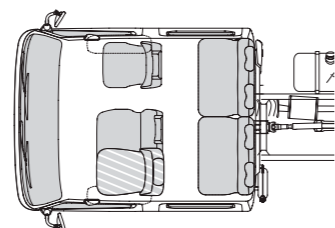

7.5t segment		7C15				7C18(D)					
Cab	Comfort				Comfort						
Cab type/seats	Single/3		Crew/7		Single/3		Crew/7				
Wheelbase (mm)	2800	3400	3850	4300	2800	3400	3850	4300	4750	3850	4750
Chassis load-bearing capacity (kg)*	4995	4960	4945	4900	5010	4960	4945	4900	4885	4725	4665
Perm. gross vehicle weight (kg)	7490				7490						
Perm. gross combination weight (kg)	10,990				10,990						
Max. output/max. torque	110kW (150hp)/370Nm				129kW (175hp)/430Nm						
Emission class	Euro VI				Euro VI						
Transmission	5-speed manual transmission/6-speed DUONIC® dual clutch transmission										
Turning circle (m)/track circle (m)	11.8/10.4	13.8/12.2	15.2/13.8	16.6/15.2	11.8/10.4	13.8/12.2	15.2/13.8	16.6/15.2	18.0/16.6	15.2/13.8	18.0/16.6

8.5t segment		9C18			
Cab	Comfort				
Cab type/seats	Single/3				
Wheelbase (mm)	3400	3850	4300	4750	
Chassis load-bearing capacity (kg)	5995	5980	5945	5925	
Perm. gross vehicle weight (kg)	8550				
Perm. gross combination weight (kg)	12,050				
Max. output/max. torque	129kW (175hp)/430Nm				
Emission class	Euro VI				
Transmission	6-speed DUONIC® dual clutch transmission				
Turning circle (m)/track circle (m)	13.8/12.2	15.2/13.8	16.6/15.2	18.0/16.6	

Side view

Single cab: 3C13, 3S13, 3C15, 3S15

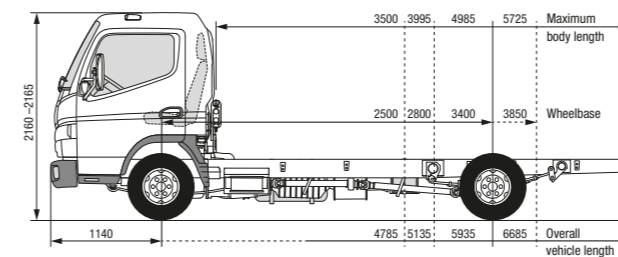

Crewcab: 3C13D, 3C15D, 7C15D, 7C18D

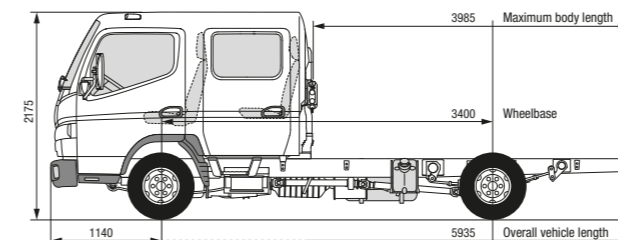

Single cab: 9C18

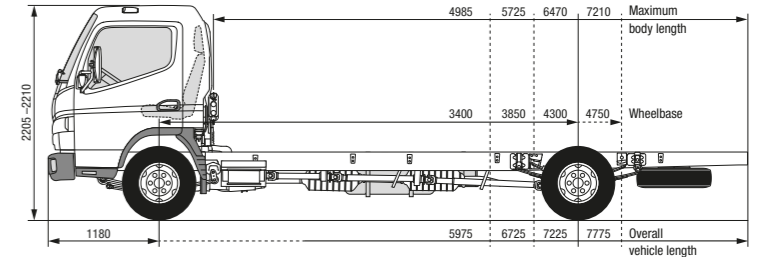

Crewcab: 7C15D

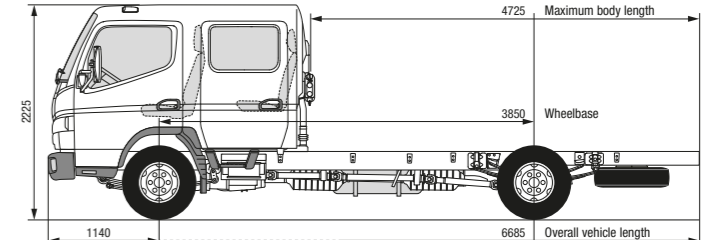

TECHNICAL DETAILS – ECO HYBRID.

7.5t segment (Eco Hybrid)	7C15	
Cab	Comfort	
Cab type/seats	Single/3	
Wheelbase	3400	3850
Chassis load-bearing capacity (kg)	4805	4790
Perm. gross vehicle weight (kg)	7490	
Perm. gross combination weight (kg)	10,990	
Max. output/max. torque	110 kW (150 hp)/370 Nm	
Emission class	Euro VI	
Electric motor	40 kW/200 Nm	
Hybrid battery	Lithium-ion 270 volt/2 kWh	
Transmission	6-speed DUONIC® dual clutch transmission	
Turning circle (m)/track circle (m)	13.8/12.2	15.2/13.8

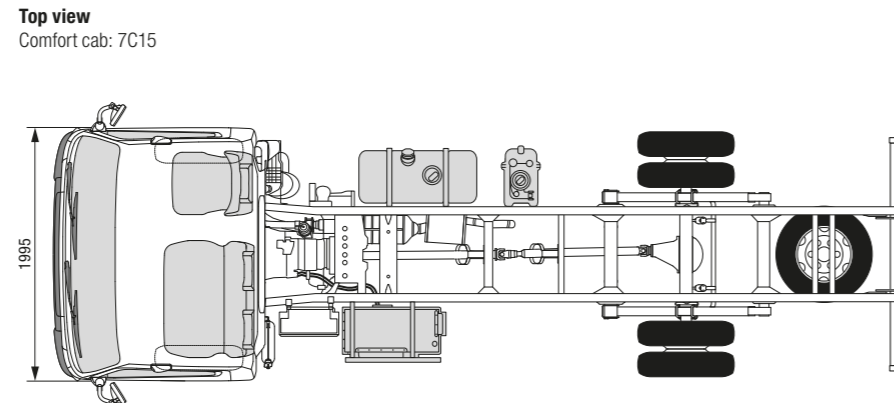
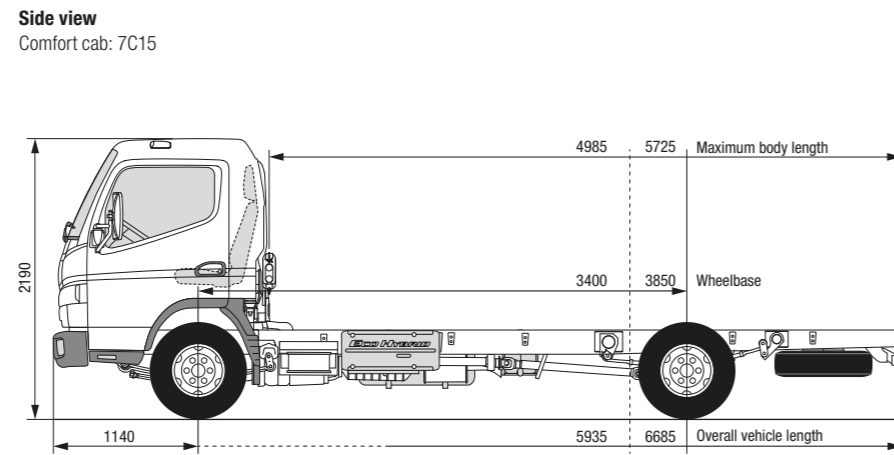
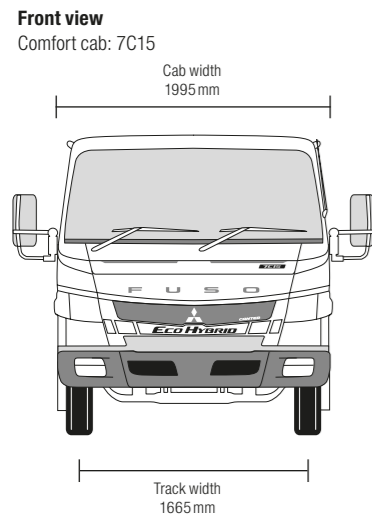

TECHNICAL DETAILS – 4x4.

6.5t segment (4x4)	6C18(D) 4x4			
Cab	Comfort			
Cab type/seats	Single/3		Crew/7	
Wheelbase	3415	3865	3415	3865
Chassis load-bearing capacity (kg)	3685	3665	3465	3445
Perm. gross vehicle weight (kg)	6500			
Perm. gross combination weight (kg)	10,000			
Angle of approach/departure	35°/25°			
Breakover angle	25°			
Ground clearance under the axles	Front/rear 210–185 mm			
Max. output/max. torque	129 kW (175 hp)/430 Nm			
Emission class	Euro VI			
Transmission	5-speed manual transmission			
Turning circle (m)/track circle (m)	14.9/13.5	16.5/15.1	14.9/13.5	16.5/15.1

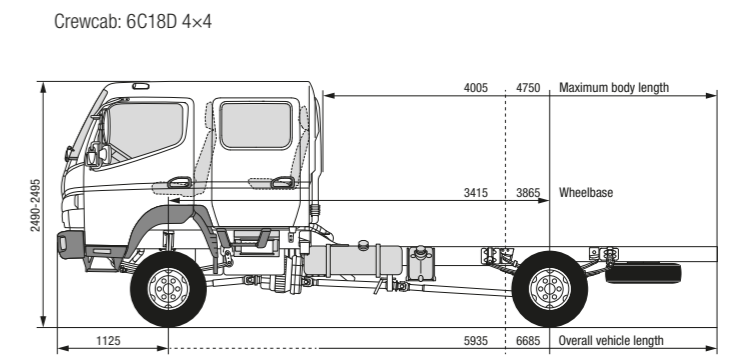
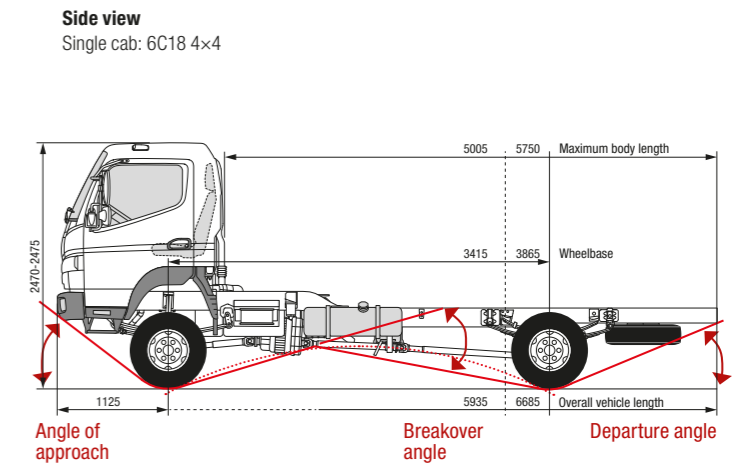
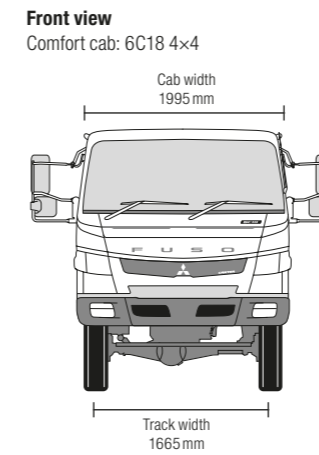

Take-back of end-of-life vehicles. Coming full circle. At the end of its long life, you can return your Canter to us for environment-friendly disposal in accordance with the EC End-Of-Life Vehicle Directive. But that day lies a long way off.

The take-back of end-of-life vehicles applies in accordance with national regulations to vehicles up to 3.5 tonnes gross weight. The Canter has met the statutory regulations governing the suitability of their design for reuse and recycling for a number of years now. A network of vehicle take-back depots and dismantlers has been established which will process your vehicle in an environment-friendly manner. The ways in which both vehicles and parts can be recovered are subject to ongoing development and improvement. Consequently, the Canter will be able to comply with any future increases in the recycling quota within the stipulated time limits.

Please note: changes may have been made to the product since this publication went to press (05/2017). The manufacturer reserves the right to make changes to the design, form, colour and specification during the delivery period, provided these changes, while taking into account the interests of the vendor, can be deemed reasonable with respect to the purchaser. Where the vendor or the manufacturer uses symbols or numbers to describe an order or the subject of an order, no rights may be derived solely from these. The illustrations may show accessories and items of special equipment which are not part of standard specification. Colours may differ slightly from those shown in the brochure, owing to the limitations of the printing process. This brochure may also contain models and services which are not available in certain countries. This brochure is distributed internationally. It provides a general indication of the range of models, features, special equipment and/or colours available in various countries. Some of the models, features, special equipment and/or colours may not be available in your country, or may only be available in a different specification. Additionally some models, features, special equipment and/or colours may only be available in combination with others. For current and more specific information in relation to the range of models, features, special equipment and/or colours available in your country, and their pricing, you should contact your nearest authorised FUSO truck dealer.

"BlueTec®" is a registered trademark of Daimler AG.

"DUONIC®" is a registered trademark of Daimler AG.

FUSO2017BR

canter.co.uk